



The Right Choice



Connecting Your Water Supplies
SINCE 1976



Heavy
Pipe Filtings

contents



01	Managing Director's Message	09	Reducing Elbow	15	Side Outlet Elbow & Tee
02	Director's Message	10	Reducing Tee	16	Plug & Back Nut
03	Process	11	Reducing Socket	17	Flange & Barrel Nipple
05	Product Features	12	Hex & Tank Nipple	18	Nozzle Nipple
07	Elbow & Tee	13	Cross & Bushing	19	Standard Packing
08	Socket & Union	14	Bend & Male / Female Elbow		

2000

- India's first unit in ISI marked Heavy Pipe Fittings to be awarded with prestigious ISO 9002:1994



DNV

1982

- Awarded with ISI Mark
- Replaced Coal Pit & Annealing Furnaces with Oil Fired Furnaces which resulted in tremendous upsurge in Output & Quality



1976

- Year of Establishment



TIMELINE 1976-PRESENT

45+ years from the Heart

2011

- Developed Electric Annealing Furnace & thus reduced the time to marked dramatically



2009

- Installation of a New Ultra Modern Manufacturing Facility 'HB Industries Unit II' to keep up with increasing demand



2005

- Replaced Oil Fired Rotary Furnaces with Electric Induction Furnaces to perfect the Quality of Castings
- Upgraded to ISO 9001:2000

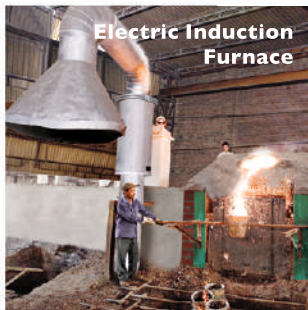

about us

Established in 1976, HB Industries is the success story of Narinder Singh Maingi and his two sons Inderjit Singh Maingi and Maninder Singh Maingi who grew to be successful entrepreneurs. The Foundation of HB Industries is laid on hard work, perseverance, passion & above all the purpose to serve the nation with **QUALITY** fittings. HB Industries has carved a unique niche in the field of pipe fittings, with the widest size range of 1/4" to 6", it has been India's largest manufacturing unit in ISI marked heavy pipe fittings for over 45 years now. The priceless feedback of customers from all over India has been incorporated into producing HB brand pipe fittings. The brand HB today stands for **BEST QUALITY, COST-EFFECTIVE, WIDEST RANGE & EXCELLENT SERVICE**. The brand image of HB is envied for its impeccable standing & trust with the customers. In India, HB is the most sought after name of its kind amongst Consumers, Customers & Vendors.

Managing Director's Message



Narinder Singh Maingi

"Quality is never an accident; it is always the result of high intention, sincere effort, intelligent direction and skillful execution; it represents the wise choice of many alternatives."

William A. Foster.

Unrelenting professional standards, abundance in experience and innovation in technology ensures that we fully address and satisfy the needs of our consumers and benefactors. Cutting edge research and openness to change won HB Industries the reputation of being technologically 'up to the minute and always future-aware'. We are a modern group that ensures the use of latest technology and infrastructure to provide BEST QUALITY at the BEST PRICE. Customer satisfaction is our highest priority.

For the past 30 years we have captained this business with vision & hard work. The benefits of this have been duly awarded, for which we are humbly grateful. It is a matter of immense pride & privilege for us as we release our revised catalogue for the information & reference, for all our valued patrons & consumers.

We take this opportunity to thank our worthy dealers, the word dealer does not explain our true relation with you, you are our family & this success story is equally yours. Together we have witnessed & sailed through the most extreme economic trends, these milestones wouldn't have been possible to achieve without your trust – 'We Value Your Trust'.

*We **must** also pay tribute to our dedicated, loyal and committed workforce. It is without a doubt, with their sincere efforts that we have been able to realise our dream and make HB Industries India's largest unit in ISI marked pipe fittings.*

A key factor of our continued success is our openness to suggestions and feedback from our consumers and peers. We believe that an out-of-box view is often the seedling of fresh, new and fruitful ideas. We welcome and continue to encourage feedback from you all.

Director's Message



Maninder Singh Maingi



Inderjit Singh Maingi

*"Everything can be improved."
C.W. Barron*

We are the privileged two that have been bequeathed the responsibility of taking HB Industries into the future. We are extremely proud of our fathers, their success is truly inspirational. We, in turn, aspire to demonstrate our individual abilities and take HB Industries to an even greater level and continue along the upward path of achievement.

*Fundamentally, we understand that growth in business means constant adaptability to time and trends. We understand that we need to respond to the market as it stands now, in the 21st century. It is understood, that to do this, we must be **vigilant to change, intelligent in response and quick to act**. Business is fast-paced and competitive, an **exciting** world to be in.*

Ours is a 3-dimensional vision, we look to grow in every aspect. We firmly believe that there is no end-point to growth. There will always be something new to achieve and excel in. We are excited to venture down 'roads undiscovered'. Not only will we introduce new products in the existing markets, but take ourselves to the markets yet unexplored both domestic and international.

*Our belief is firm, that is, we have always been a customer orientated company. The company will continue to place a great emphasis on customer support. We plan to persist with strong marketing campaigns with our 'message' clear and concise, HB – **the 'go to' people** for pipe fittings, valves and cocks. We are a customer friendly and easy to access group, dedicated actions will be introduced in order to enhance our relationship further. We love our customers, you are our first priority!*

*"The best way to predict the future is to create it."
Peter Drucker*

PROCESS

Computer Aided Design

1 →



Raw Material

2 →



Chemical Analysis

3



Shell Core Preparation

4 →



Electric Induction Furnace

5 →



Oil Fired Annealing Furnace

6



Electric Annealing Furnace

7 →



Compression Test

8 →



Grinding Process

9 →



Shot Blast

10 →



Hot Dip Galvanising

11 →



Chamfering

12 →



Machining & Threading

13 →



Angle Alignment Inspection

14 →



Drying & Cleaning Process

15 →



Hydraulic Pressure Testing

16 →



Pre Delivery Inspection

17 →



Gunny Bag Packing

18 →



Final Dispatch of Goods

19 →



PRODUCT FEATURES

HB BRAND PIPE FITTINGS - A WORD :

HB brand pipe fittings follow the plus tolerance of BIS specifications. HB brand pipe fittings are approved & regularly used on all the major govt., semi govt., commercial and domestic piping systems through out India. They enjoy a reputation of being the ULTIMATE IN QUALITY. This reputation has been made possible by company's image of producing consistently accurate and reliable quality fittings combined with their very efficient sales and after-sales network throughout India. HB brand pipe fittings are subjected to rigid inspection at various stages of manufacturing to ensure their reliability. Hence they are being used for industrial, agricultural, domestic, commercial and other piping installations on ground, underground and concealed without the fear of faults and the rectifications there of.

Description : A brief Description of HB brand pipe fittings with their code designations are as follows :

(a) Elbow & Reducing Elbow	A1	(h) Side outlet Tee (4 Way)	Za2
(b) Tee & Reducing Tee	B1	(i) Short Bend (Long sweep Bend)	G4
(c) Socket & Reducing Socket	M2	(j) Plug	T8
(d) Union	U1	(k) Bushing	N4
(e) Hex Nipple	N8	(l) Backnut	P4
(f) Cross	C1	(m) Male & female Elbow	A4
(g) Side outlet Elbow (3 Way)	Za1	(n) Tank Nipple	

Size Designation : Size designations are determined by the nominal inch sizes of threads at the outlet of fittings. HB brand pipe fittings are normally manufactured from 1/4" to 6" sizes.

Equal Fittings : The fittings of which the nominal inlet & outlet diameters are of the same size are referred to as equal fittings.

Unequal Fittings : The fittings of which the nominal inlet and outlet diameters differ are referred to as unequal fittings. To denote the sizes in case of such fittings, the bigger diameter is indicated first and then the smaller diameter e.g. 1"x3/4" or 1"x3/4"x1".

Union : Unions are flat-seated & are supplied with rubber gaskets.

Specifications : HB brand pipe fittings conform to the following specifications.

Dimensions : Malleable cast iron pipe fittings as per IS 1879 - 1987 (Part 1 to X).

Material : Black heart malleable cast iron as per 14329-1995 grade BM -300

Threads : Threaded as per IS : 554-199 parallel female & taper male threads to bear pressure tight joints.

Finish : Hot dip galvanized finish tested in accordance with provisions contained in IS : 2633-1986 & IS : 6745-1972.

Quality Controls : To control and maintain the required quality, the following tests are performed :

(A) CHEMICAL TESTING : (i) Raw materials such as pig iron, steel scrap and zinc are tested for their required chemical compositions prior to melting, in a well equipped testing laboratory. Molasses & sand are also tested for their required properties.

(ii) Raw castings are chemically tested for the required chemical compositions.

(iii) Galvanized casting are tested to ensure that the zinc coating is not less than the specified 610 gms/m² as per IS : 4759-1996.

(B) VISUAL INSPECTIONS : (i) Raw casting are subject to strict visual inspections to ensure that they are sound, clean, free from porosity, blow holes, hard spots, cold shuts, distortions, misruns and sand drops etc.

(ii) Annealed, grinded and shot blasted casting are inspected for cracks and distortions.

(iii) Galvanized castings are inspected to ensure that the zinc coating is smooth, clean, uniform, free from acid spots, black spots and pimples.

(iv) Thread inspections are carried out to ensure that the machined fittings are free from defects on threaded portions such as thin threads, broken threads & pin holes.

(C) MECHANICAL TESTS (By Sampling Method) : To ensure that the fitting have acquired the requisite properties, the following mechanical test are performed.

(i) Malleability Test : To ensure that the fittings have acquired proper malleability,

(ii) Tensile Test : To ensure that the fittings are annealed & have attained the required tensile strength & elongation.

(iii) Pressure Test : To ensure that the fittings are leakproof when subjected to internal fluid & air pressure.

(D) METRO LOGICAL INSPECTIONS : Metrological inspection is done to ensure that the fittings have acquired correct alignment, overall diameters, wall thickness with the help of suitable thread gauges & micrometers etc.

Marking :  is a registered trade mark, appears on all fittings except where it is not possible for technical reasons.

Packing :  brand pipe fittings are packed in double gunny bags with an additional polythene bag inserted to ensure their complete protection in all weather conditions. Details of standard per bag packing can be furnished on request.

Technical Parameters : The following table highlights the technical superiority of  brand pipe fittings vis-a-vis the national & international standards.

Specifications :	HB	BIS	ISO	JIS	BS
Tensile strength (Min.) Mpa	320	300	300	280	280
Elongation (Min.) (%age)	10	6	6	5	6
Zinc coating (Min.) (gms/m ²)	810	610	450	-	450
Hydraulic Working Pressure (Max.) Mpa	2.9	2.1	2.0	2.0	1.4
Hardness (Max) (HB)	120to140	150	-	-	-
Angle Tolerance Degree (+/-)	0.40	0.50	0.50	0.40	0.45

SPECIAL FEATURES :



Malleability :  brand pipe fittings are manufactured under strict process controls in melting & heat treatment which enable them to achieve better malleability, ductility alongwith requisite strength, The right combination of strength and ductility ensure them to resist higher pressure without any breakages or leakages.

Accurate Threading :  brand pipe fittings are threaded on special purpose machines to ensure close tolerance limits of thread dimensions which lead to their close contacts with pipes, valves & cocks etc. and as such there remains no chance of leakage.

Chamfering :  brand pipe fittings are chamfered slightly on every thread opening to enable easy and correct entrance of pipes, valves & cocks etc. it also ensures easy engagement of first thread.

Hot Dip Galvanizing : Pure zinc is used employing hot dip technique for galvanising  brand pipe fittings. Hot dip galvanising rechnique ensures zinc coating to be uniform, smooth, clean, free from black spots, acid spots and pimples. Hence the resultant thick & continuous coating of zinc gives them extra protection against environmental corrosion.

ADVANTAGES OF USING BRAND PIPE FITTINGS :

 brand pipe fittings achieve the highest standards in malleability, thus they withstand the higher tightening force applied. Hence they do not crack or break while screwing on to pipes, valves and cocks etc. Accurate threading of  brand pipe fittings needs no rework on them at the site & are quickly assembled on to the pipes, valves & cocks etc., resulting in considrable saving of time and labour, The perfect alignment of threads  brand pipe fittings connect the pipes at the required angles of 90° or 180° , thus making piping systems free from any additional strain. it also ensure correct flow of water, liquids, oils, steam, gases etc.

 brand pipe fittings are given zinc coating by hot dip galvanizing technique, The resultant uniform and thick coating of zinc provides extra protection against environmental corrosion in abnormal conditions. Hence they need no additional protective coating of paints etc.

SCOPE OF APPLICATIONS :

 brand pipe fittings have very wide scope of applications & are regularly used on water, oil, steam, air and gas piping system such as :

- Sanitary and Air conditioning Installations in residential as well as commercial buildings.
- Erection & Maintenance of Equipment & Pipes for fluids
- Recycling & Cooling Systems
- Oil Systems
- Hydraulic & Pneumatic Circuits
- Stationery Equipment
- Fire Prevention Systems
- Thermal & Refrigeration Equipments & several other similar Industrial Piping Systems
- Urban and village Water Supply Schemes
- Domestic Gas & Bio Gas Supply Projects etc.

Elbow - A1

90° Female, Equal

- Follow plus tolerance of BIS.
- Hot galvanised with thick uniform zinc coating.
- Accurate threading & perfectly angled to 90°.
- Superior grade malleability to ensure crack free installation.

NOMINAL SIZE (inches)	SPECIFIED DIMENSIONS & TOLERANCE (a)	OBSERVED DIMENSIONS (a)	SPECIFIED WALL THICKNESS & TOLERANCE	OBSERVED WALL THICKNESS
1/4	21 ± 1.5	22.5	2.5 -0.5	4.0
3/8	25 ± 1.5	26.5	2.5 -0.5	3.2
1/2	28 ± 1.5	29.0	2.5 -0.5	4.0
3/4	33 ± 2.0	34.5	3.0 -0.7	4.0
1	38 ± 2.0	39.5	3.0 -0.7	4.0
1¼	45 ± 2.0	45.7	3.5 -0.7	4.0
1½	50 ± 2.0	50.7	3.5 -0.7	4.0
2	58 ± 2.5	59.0	4.0 -0.7	5.0
2½	69 ± 2.5	69.3	4.5 -1.0	5.5
3	78 ± 3.0	79.5	5.0 -1.0	5.5
4	96 ± 3.0	96.7	6.0 -1.0	7.0
5	115 ± 3.5	117.0	6.5 -1.0	8.0
6	131 ± 3.5	131.0	7.5 -1.0	8.0
8	- -	165.0	- -	10.0

All dimensions are in mm



Technical Drawing
DRAWING

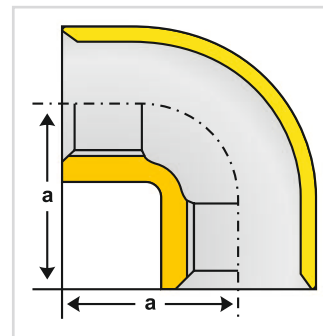

Tee - B1

90° Female, Equal

- Follow plus tolerance of BIS.
- Hot galvanised with thick uniform zinc coating.
- Accurate threading & perfectly angled to 90°.
- Superior grade malleability to ensure crack free installation.

NOMINAL SIZE (inches)	SPECIFIED DIMENSIONS & TOLERANCE (a)	OBSERVED DIMENSIONS (a)	SPECIFIED WALL THICKNESS & TOLERANCE	OBSERVED WALL THICKNESS
1/4	21 ± 1.5	22.3	2.5 -0.5	3.5
3/8	25 ± 1.5	25.4	2.5 -0.5	3.0
1/2	28 ± 1.5	29.0	2.5 -0.5	4.0
3/4	33 ± 2.0	34.6	3.0 -0.7	4.0
1	38 ± 2.0	39.2	3.0 -0.7	3.5
1¼	45 ± 2.0	45.5	3.5 -0.7	3.5
1½	50 ± 2.0	51.3	3.5 -0.7	4.2
2	58 ± 2.5	58.0	4.0 -0.7	4.5
2½	69 ± 2.5	69.0	4.5 -1.0	5.0
3	78 ± 3.0	78.0	5.0 -1.0	5.0
4	96 ± 3.0	96.5	6.0 -1.0	6.0
5	115 ± 3.5	115.5	6.5 -1.0	8.0
6	131 ± 3.5	131.5	7.5 -1.0	8.0
8	- -	165.0	- -	10.0

All dimensions are in mm



Technical Drawing
DRAWING

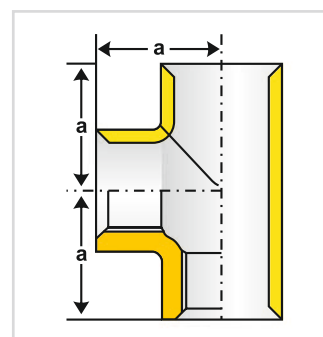

Socket - M2

180° Female, Equal, Ribbed

- Follow plus tolerance of BIS.
- Hot galvanised with thick uniform zinc coating.
- Accurate threading & perfectly angled to 180°.
- Superior grade malleability to ensure crack free installation.

NOMINAL SIZE (inches)	SPECIFIED DIMENSIONS & TOLERANCE (a)	OBSERVED DIMENSIONS (a)	SPECIFIED WALL THICKNESS & TOLERANCE	OBSERVED WALL THICKNESS
1/4	27 ± 1.5	28.5	2.5 -0.5	3.0
3/8	30 ± 1.5	31.0	2.5 -0.5	3.0
1/2	36 ± 2.0	36.5	2.5 -0.5	3.8
3/4	39 ± 2.0	39.5	3.0 -0.7	3.9
1	45 ± 2.0	46.0	3.0 -0.7	3.9
1¼	50 ± 2.0	50.5	3.5 -0.7	4.2
1½	55 ± 2.5	56.0	3.5 -0.7	4.0
2	65 ± 2.5	66.0	4.0 -0.7	4.0
2½	71 ± 2.5	72.4	4.5 -1.0	4.5
3	78 ± 3.0	80.0	5.0 -1.0	6.0
4	94 ± 3.0	95.5	6.0 -1.0	6.0
5	109 ± 3.5	110.5	6.5 -1.0	8.0
6	120 ± 3.5	120.0	7.5 -1.0	8.0
8	- -	128.0	- -	10.0

All dimensions are in mm



Technical Drawing
DRAWING

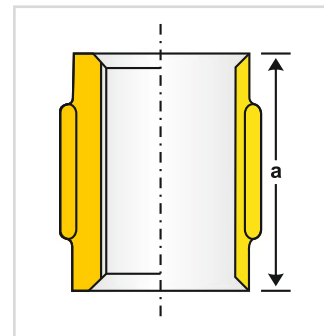

Union - U1

180° Female, Equal

- Follow plus tolerance of BIS.
- Hot galvanised with thick uniform zinc coating.
- Accurate threading & perfectly angled to 180°.
- Superior grade malleability to ensure crack free installation.

NOMINAL SIZE (inches)	SPECIFIED DIMENSIONS & TOLERANCE (a)	OBSERVED DIMENSIONS (a)	SPECIFIED WALL THICKNESS & TOLERANCE	OBSERVED WALL THICKNESS
1/4	42 ± 2.0	42.0	2.5 -0.5	3.0
3/8	45 ± 2.0	45.0	2.5 -0.5	3.0
1/2	48 ± 2.0	48.5	2.5 -0.5	3.0
3/4	52 ± 2.5	53.0	3.0 -0.7	3.2
1	58 ± 2.5	59.0	3.0 -0.7	4.0
1¼	65 ± 2.5	66.0	3.5 -0.7	4.0
1½	70 ± 2.5	70.5	3.5 -0.7	4.0
2	78 ± 3.0	78.0	4.0 -0.7	4.2
2½	85 ± 3.0	85.5	4.5 -1.0	6.0
3	95 ± 3.0	97.0	5.0 -1.0	6.0
4	110 ± 3.5	110.5	6.0 -1.0	6.0
5	135 ± 3.5	135.0	6.5 -1.0	7.5
6	150 ± 3.5	150.0	7.5 -1.0	8.0

All dimensions are in mm



Technical Drawing
DRAWING

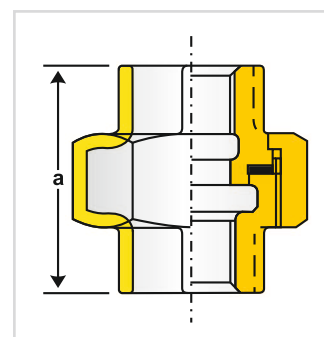

Reducing Elbow - A1

90° Female, Reducing

- Follow plus tolerance of BIS.
- Hot galvanised with thick uniform zinc coating.
- Accurate threading & perfectly angled to 90°.
- Superior grade malleability to ensure crack free installation.



NOMINAL SIZE (inches)	SPECIFIED DIMENSIONS & TOLERANCE (a)	OBSERVED DIMENSIONS (a)	SPECIFIED DIMENSIONS & TOLERANCE (b)	OBSERVED DIMENSIONS (b)	SPECIFIED WALL THICKNESS & TOLERANCE	OBSERVED WALL THICKNESS
3/8 x 1/4	23 ± 1.5	23.0	23 ± 1.5	23.2	2.5 -0.5	2.9
1/2 x 1/4	24 ± 1.5	25.1	24 ± 1.5	25.2	2.5 -0.5	3.0
1/2 x 3/8	26 ± 1.5	27.5	26 ± 1.5	26.5	2.5 -0.5	3.0
3/4 x 1/2	30 ± 1.5	30.5	31 ± 2.0	31.6	3.0 -0.7	4.5
1 x 1/2	32 ± 2.0	32.1	34 ± 2.0	35.0	3.0 -0.7	4.0
1 x 3/4	35 ± 2.0	35.5	36 ± 2.0	37.5	3.0 -0.7	4.0
1 1/4 x 1/2	34 ± 2.0	34.0	38 ± 2.0	40.0	3.5 -0.7	3.5
1 1/4 x 3/4	36 ± 2.0	36.0	41 ± 2.0	41.5	3.5 -0.7	4.0
1 1/4 x 1	40 ± 2.0	40.0	42 ± 2.0	43.0	3.5 -0.7	4.0
1 1/2 x 1/2	36 ± 2.0	36.2	42 ± 2.0	42.0	3.5 -0.7	4.0
1 1/2 x 3/4	38 ± 2.0	39.7	44 ± 2.0	44.3	3.5 -0.7	4.5
1 1/2 x 1	42 ± 2.0	42.0	46 ± 2.0	46.0	3.5 -0.7	4.5
1 1/2 x 1 1/4	46 ± 2.0	46.4	48 ± 2.0	48.2	3.5 -0.7	4.5
2 x 1/2	38 ± 2.0	38.5	48 ± 2.0	49.8	4.0 -0.7	4.0
2 x 3/4	40 ± 2.0	40.6	50 ± 2.0	51.4	4.0 -0.7	4.0
2 x 1	44 ± 2.0	44.0	52 ± 2.5	52.1	4.0 -0.7	5.0
2 x 1 1/4	48 ± 2.0	49.0	54 ± 2.5	55.5	4.0 -0.7	5.0
2 x 1 1/2	52 ± 2.5	53.0	55 ± 2.5	55.5	4.0 -0.7	5.5
2 1/2 x 1/2	41 ± 2.0	41.8	57 ± 2.5	57.0	4.5 -1.0	6.0
2 1/2 x 3/4	44 ± 2.0	44.0	59 ± 2.5	59.0	4.5 -1.0	6.0
2 1/2 x 1	47 ± 2.0	47.9	60 ± 2.5	60.2	4.5 -1.0	6.2
2 1/2 x 1 1/4	52 ± 2.5	52.5	62 ± 2.5	62.0	4.5 -1.0	6.0
2 1/2 x 1 1/2	55 ± 2.5	55.4	63 ± 2.5	63.0	4.5 -1.0	6.0
2 1/2 x 2	61 ± 2.5	61.1	66 ± 2.5	66.0	4.5 -1.0	5.1
3 x 1/2	45 ± 2.0	46.2	64 ± 2.5	64.0	5.0 -1.0	5.5
3 x 3/4	47 ± 2.0	47.0	66 ± 2.5	66.1	5.0 -1.0	5.5
3 x 1	51 ± 2.5	51.0	67 ± 2.5	67.2	5.0 -1.0	6.0
3 x 1 1/4	55 ± 2.5	55.0	70 ± 2.5	70.0	5.0 -1.0	6.0
3 x 1 1/2	57 ± 2.5	57.0	71 ± 2.5	72.0	5.0 -1.0	6.0
3 x 2	63 ± 2.5	64.7	73 ± 2.5	74.3	5.0 -1.0	6.0
3 x 2 1/2	71 ± 2.5	71.3	76 ± 3.0	76.4	5.0 -1.0	6.5
4 x 1/2	50 ± 2.0	50.5	78 ± 3.0	78.5	6.0 -1.0	6.5
4 x 3/4	56 ± 2.5	56.5	80 ± 3.0	80.5	6.0 -1.0	6.5
4 x 1	58 ± 2.5	58.0	81 ± 3.0	83.2	6.0 -1.0	6.0
4 x 1 1/4	62 ± 2.5	62.0	83 ± 3.0	83.0	6.0 -1.0	6.0
4 x 1 1/2	64 ± 2.5	64.7	85 ± 3.0	85.5	6.0 -1.0	6.5
4 x 2	68 ± 2.5	70.0	86 ± 3.0	86.0	6.0 -1.0	6.0
4 x 2 1/2	76 ± 3.0	76.7	90 ± 3.0	90.0	6.0 -1.0	6.0
4 x 3	85 ± 3.0	85.0	93 ± 3.0	93.0	6.0 -1.0	6.0

Technical Drawing

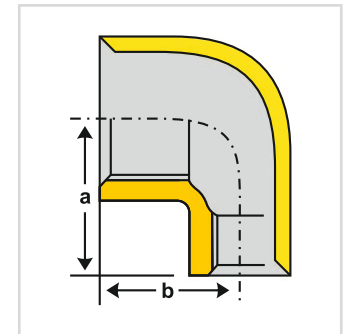

All dimensions are in mm

Reducing Tee - B1

90° Female, Reducing

- Follow plus tolerance of BIS.
- Hot galvanised with thick uniform zinc coating.
- Accurate threading & perfectly angled to 90°.
- Superior grade malleability to ensure crack free installation.

Technical Drawing
DRAWING

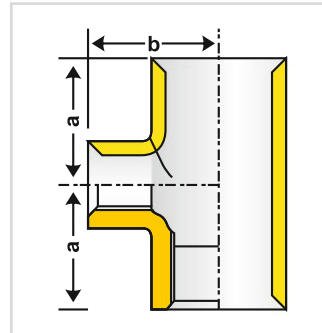

NOMINAL SIZE (inches)	SPECIFIED DIMENSIONS & TOLERANCE (a)	OBSERVED DIMENSIONS (a)	SPECIFIED DIMENSIONS & TOLERANCE (b)	OBSERVED DIMENSIONS (b)	SPECIFIED WALL THICKNESS & TOLERANCE	OBSERVED WALL THICKNESS
3/8 x 1/4 x 3/8	23 ± 1.5	23.5	23 ± 1.5	23.5	2.5 -0.5	3.0
1/2 x 1/4 x 1/2	24 ± 1.5	25.5	24 ± 1.5	24.3	2.5 -0.5	3.5
1/2 x 3/8 x 1/2	26 ± 1.5	27.4	26 ± 1.5	27.6	2.5 -0.5	3.1
3/4 x 1/2 x 3/4	30 ± 1.5	31.0	31 ± 2.0	31.9	3.0 -0.7	4.0
1 x 1/4 x 1	28 ± 1.5	28.5	31 ± 2.0	31.5	3.0 -0.7	4.0
1 x 3/8 x 1	30 ± 1.5	30.5	32 ± 2.0	32.5	3.0 -0.7	4.0
1 x 1/2 x 1	32 ± 2.0	33.0	34 ± 2.0	34.5	3.0 -0.7	4.0
1 x 3/4 x 1	35 ± 2.0	35.0	36 ± 2.0	36.5	3.0 -0.7	3.7
1 1/4 x 1/2 x 1 1/4	34 ± 2.0	34.9	38 ± 2.0	40.4	3.5 -0.7	4.0
1 1/4 x 3/4 x 1 1/4	36 ± 2.0	37.0	41 ± 2.0	42.0	3.5 -0.7	3.7
1 1/4 x 1 x 1 1/4	40 ± 2.0	41.5	42 ± 2.0	43.5	3.5 -0.7	4.5
1 1/2 x 1/2 x 1 1/2	36 ± 2.0	36.7	42 ± 2.0	43.3	3.5 -0.7	4.5
1 1/2 x 3/4 x 1 1/2	38 ± 2.0	39.2	44 ± 2.0	45.0	3.5 -0.7	4.0
1 1/2 x 1 x 1 1/2	42 ± 2.0	42.5	46 ± 2.0	45.6	3.5 -0.7	4.0
1 1/2 x 1 1/4 x 1 1/2	46 ± 2.0	46.7	48 ± 2.0	48.0	3.5 -0.7	3.9
2 x 1/2 x 2	38 ± 2.0	39.0	48 ± 2.0	50.0	4.0 -0.7	5.0
2 x 3/4 x 2	40 ± 2.0	41.3	50 ± 2.0	52.0	4.0 -0.7	4.0
2 x 1 x 2	44 ± 2.0	45.0	52 ± 2.5	52.5	4.0 -0.7	4.5
2 x 1 1/4 x 2	48 ± 2.0	49.1	54 ± 2.5	55.2	4.0 -0.7	4.5
2 x 1 1/2 x 2	52 ± 2.5	52.6	55 ± 2.5	57.0	4.0 -0.7	4.3
2 1/2 x 1/2 x 2 1/2	41 ± 2.0	41.6	57 ± 2.5	58.5	4.5 -1.0	5.0
2 1/2 x 3/4 x 2 1/2	44 ± 2.0	45.3	59 ± 2.5	60.3	4.5 -1.0	5.0
2 1/2 x 1 x 2 1/2	47 ± 2.0	48.5	60 ± 2.5	61.5	4.5 -1.0	5.0
2 1/2 x 1 1/4 x 2 1/2	52 ± 2.5	53.7	62 ± 2.5	63.7	4.5 -1.0	5.0
2 1/2 x 1 1/2 x 2 1/2	55 ± 2.5	55.6	63 ± 2.5	65.0	4.5 -1.0	4.8
2 1/2 x 2 x 2 1/2	61 ± 2.5	61.5	66 ± 2.5	67.1	4.5 -1.0	4.7
3 x 1/2 x 3	45 ± 2.0	45.0	64 ± 2.5	65.6	5.0 -1.0	5.5
3 x 3/4 x 3	47 ± 2.0	47.8	66 ± 2.5	67.0	5.0 -1.0	5.5

All dimensions are in mm

NOMINAL SIZE (inches)	SPECIFIED DIMENSIONS & TOLERANCE (a)	OBSERVED DIMENSIONS (a)	SPECIFIED DIMENSIONS & TOLERANCE (b)	OBSERVED DIMENSIONS (b)	SPECIFIED WALL THICKNESS & TOLERANCE	OBSERVED WALL THICKNESS
3 x 1 x 3	51 ± 2.5	52.0	67 ± 2.5	69.0	5.0 -1.0	5.0
3 x 1 1/4 x 3	55 ± 2.5	56.0	70 ± 2.5	70.0	5.0 -1.0	5.0
3 x 1 1/2 x 3	58 ± 2.5	59.5	71 ± 2.5	71.2	5.0 -1.0	5.0
3 x 2 x 3	64 ± 2.5	64.4	73 ± 2.5	73.2	5.0 -1.0	5.2
3 x 2 1/2 x 3	72 ± 2.5	73.2	76 ± 3.0	77.3	5.0 -1.0	5.2
4 x 1/2 x 4	50 ± 2.0	51.5	78 ± 3.0	78.0	6.0 -1.0	6.0
4 x 3/4 x 4	56 ± 2.5	56.0	80 ± 3.0	80.0	6.0 -1.0	7.0
4 x 1 x 4	58 ± 2.5	58.0	81 ± 3.0	82.9	6.0 -1.0	6.6
4 x 1 1/4 x 4	58 ± 2.5	60.5	82 ± 3.0	84.0	6.0 -1.0	6.5
4 x 1 1/2 x 4	64 ± 2.5	65.5	85 ± 3.0	87.5	6.0 -1.0	6.5
4 x 2 x 4	70 ± 2.5	70.3	86 ± 3.0	87.5	6.0 -1.0	6.5
4 x 2 1/2 x 4	76 ± 3.0	76.7	90 ± 3.0	90.0	6.0 -1.0	6.5
4 x 3 x 4	84 ± 3.0	86.0	92 ± 3.0	93.5	6.0 -1.0	6.5
5 x 1 x 5	61 ± 2.5	61.0	95 ± 3.0	95.0	6.5 -1.0	6.8
5 x 1 1/4 x 5	65 ± 2.5	65.0	97 ± 3.0	97.0	6.5 -1.0	7.0
5 x 1 1/2 x 5	68 ± 2.5	68.0	99 ± 3.0	99.0	6.5 -1.0	6.8
5 x 2 x 5	74 ± 2.5	74.0	100 ± 3.0	100.0	6.5 -1.0	6.8
5 x 2 1/2 x 5	81 ± 3.0	81.0	104 ± 3.5	104.0	6.5 -1.0	7.0
5 x 3 x 5	89 ± 3.0	89.0	107 ± 3.5	107.0	6.5 -1.0	7.0
5 x 4 x 5	103 ± 3.5	103.0	110 ± 3.5	110.0	6.5 -1.0	7.0
6 x 1 x 6	62 ± 2.5	62.0	108 ± 3.5	108.0	7.5 -1.0	7.8
6 x 1 1/4 x 6	68 ± 2.5	68.0	112 ± 3.5	112.0	7.5 -1.0	7.8
6 x 1 1/2 x 6	71 ± 2.5	71.0	114 ± 3.5	114.0	7.5 -1.0	8.0
6 x 2 x 6	77 ± 3.0	77.0	115 ± 3.5	115.0	7.5 -1.0	8.0
6 x 2 1/2 x 6	85 ± 3.0	85.0	118 ± 3.5	118.0	7.5 -1.0	7.8
6 x 3 x 6	91 ± 3.0	91.0	119 ± 3.5	119.0	7.5 -1.0	8.0
6 x 4 x 6	105 ± 3.5	105.0	125 ± 3.5	125.0	7.5 -1.0	8.0
6 x 5 x 6	118 ± 3.5	118.0	130 ± 3.5	130.0	7.5 -1.0	8.0

All dimensions are in mm

Reducing Socket - M2

180° Female, Reducing

- Follow plus tolerance of BIS.
- Hot galvanised with thick uniform zinc coating.
- Accurate threading & perfectly angled to 180°.
- Superior grade malleability to ensure crack free installation.

Technical Drawing

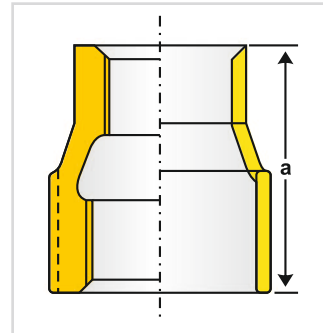

NOMINAL SIZE (inches)	SPECIFIED DIMENSIONS & TOLERANCE (a)	OBSERVED DIMENSIONS (a)	SPECIFIED WALL THICKNESS & TOLERANCE	OBSERVED WALL THICKNESS
3/8 x 1/4	30 ± 1.5	30.5	2.5 -0.5	2.7
1/2 x 1/4	36 ± 2.0	36.0	2.5 -0.5	3.2
1/2 x 3/8	36 ± 2.0	36.0	2.5 -0.5	3.1
3/4 x 1/2	39 ± 2.0	40.0	3.0 -0.7	4.0
1 x 1/4	45 ± 2.0	45.4	3.0 -0.7	3.5
1 x 3/8	45 ± 2.0	45.5	3.0 -0.7	3.5
1 x 1/2	45 ± 2.0	45.9	3.0 -0.7	3.8
1 x 3/4	45 ± 2.0	45.9	3.0 -0.7	3.9
1 1/4 x 1/2	50 ± 2.0	50.4	3.5 -0.7	4.0
1 1/4 x 3/4	50 ± 2.0	50.1	3.5 -0.7	4.1
1 1/4 x 1	50 ± 2.0	50.8	3.5 -0.7	4.5
1 1/2 x 1/2	55 ± 2.5	55.4	3.5 -0.7	4.5
1 1/2 x 3/4	55 ± 2.5	55.8	3.5 -0.7	4.2
1 1/2 x 1	55 ± 2.5	55.0	3.5 -0.7	4.0
1 1/2 x 1 1/4	55 ± 2.5	55.0	3.5 -0.7	4.2
2 x 1/2	65 ± 2.5	65.0	4.0 -0.7	5.0
2 x 3/4	65 ± 2.5	65.0	4.0 -0.7	4.8
2 x 1	65 ± 2.5	65.0	4.0 -0.7	5.0
2 x 1 1/4	65 ± 2.5	65.0	4.0 -0.7	5.0
2 x 1 1/2	65 ± 2.5	65.0	4.0 -0.7	4.2
2 1/2 x 1/2	71 ± 2.5	72.3	4.5 -1.0	4.5
2 1/2 x 3/4	71 ± 2.5	73.5	4.5 -1.0	4.7
2 1/2 x 1	74 ± 2.5	74.7	4.5 -1.0	4.5
2 1/2 x 1 1/4	74 ± 2.5	75.0	4.5 -1.0	5.0
2 1/2 x 1 1/2	74 ± 2.5	74.5	4.5 -1.0	4.7
2 1/2 x 2	74 ± 2.5	76.0	4.5 -1.0	4.8
3 x 1/2	78 ± 3.0	78.4	5.0 -1.0	5.0
3 x 3/4	78 ± 3.0	78.0	5.0 -1.0	5.5

All dimensions are in mm

NOMINAL SIZE (inches)	SPECIFIED DIMENSIONS & TOLERANCE (a)	OBSERVED DIMENSIONS (a)	SPECIFIED WALL THICKNESS & TOLERANCE	OBSERVED WALL THICKNESS
3 x 1	78 ± 3.0	81.0	5.0 -1.0	5.0
3 x 1 1/4	78 ± 3.0	80.0	5.0 -1.0	5.5
3 x 1 1/2	80 ± 3.0	83.0	5.0 -1.0	5.5
3 x 2	80 ± 3.0	82.5	5.0 -1.0	5.5
3 x 2 1/2	80 ± 3.0	83.0	5.0 -1.0	6.0
4 x 1/2	94 ± 3.0	94.0	6.0 -1.0	6.0
4 x 3/4	94 ± 3.0	94.0	6.0 -1.0	6.0
4 x 1	94 ± 3.0	94.0	6.0 -1.0	6.0
4 x 1 1/4	94 ± 3.0	94.0	6.0 -1.0	6.0
4 x 1 1/2	94 ± 3.0	95.0	6.0 -1.0	6.0
4 x 2	94 ± 3.0	96.0	6.0 -1.0	6.0
4 x 2 1/2	94 ± 3.0	96.0	6.0 -1.0	6.0
4 x 3	94 ± 3.0	95.0	6.0 -1.0	6.0
5 x 1	109 ± 3.5	109.0	6.5 -1.0	6.6
5 x 1 1/4	109 ± 3.5	109.0	6.5 -1.0	6.8
5 x 1 1/2	109 ± 3.5	109.0	6.5 -1.0	6.5
5 x 2	109 ± 3.5	109.0	6.5 -1.0	6.8
5 x 2 1/2	109 ± 3.5	109.0	6.5 -1.0	7.0
5 x 3	109 ± 3.5	109.0	6.5 -1.0	7.0
5 x 4	109 ± 3.5	109.0	6.5 -1.0	6.8
6 x 1	120 ± 3.5	120.0	7.5 -1.0	7.5
6 x 1 1/4	120 ± 3.5	120.0	7.5 -1.0	7.8
6 x 1 1/2	120 ± 3.5	120.0	7.5 -1.0	7.8
6 x 2	120 ± 3.5	120.0	7.5 -1.0	8.0
6 x 2 1/2	120 ± 3.5	120.0	7.5 -1.0	7.7
6 x 3	120 ± 3.5	120.0	7.5 -1.0	7.9
6 x 4	120 ± 3.5	120.0	7.5 -1.0	8.0
6 x 5	120 ± 3.5	120.0	7.5 -1.0	8.0

All dimensions are in mm

Hex Nipple - N8

180° Male, Equal

- Follow plus tolerance of BIS.
- Hot galvanised with thick uniform zinc coating.
- Accurate threading & perfectly angled to 180°.
- Superior grade malleability to ensure crack free installation.



NOMINAL SIZE (inches)	SPECIFIED DIMENSIONS & TOLERANCE (a)	OBSERVED DIMENSIONS (a)	SPECIFIED WALL THICKNESS & TOLERANCE	OBSERVED WALL THICKNESS
1/2	44 ± 2.0	44.0	2.5 -0.5	2.6
3/4	47 ± 2.0	47.5	3.0 -0.7	3.5
1	53 ± 2.5	54.0	3.0 -0.7	3.5
1¼	57 ± 2.5	58.0	3.5 -0.7	4.0
1½	59 ± 2.5	59.5	3.5 -0.7	3.8
2	68 ± 2.5	69.5	4.0 -0.7	4.4
2½	75 ± 2.5	76.0	4.5 -1.0	5.9
3	83 ± 3.0	83.0	5.0 -1.0	6.0
4	95 ± 3.0	96.0	6.0 -1.0	7.2

All dimensions are in mm

Technical Drawing
DRAWING

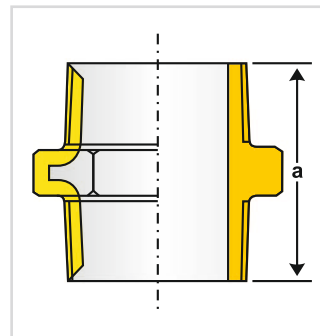

Tank Nipple

180° Male, Equal

- Follow plus tolerance of BIS.
- Hot galvanised with thick uniform zinc coating.
- Accurate threading & perfectly angled to 180°.
- Superior grade malleability to ensure crack free installation.



NOMINAL SIZE (inches)	SPECIFIED DIMENSIONS & TOLERANCE (a)	OBSERVED DIMENSIONS (a)	SPECIFIED WALL THICKNESS & TOLERANCE	OBSERVED WALL THICKNESS
1/2	65 ± 2.5	65.5	2.5 -0.5	3.0
3/4	70 ± 2.5	72.0	3.0 -0.7	3.5
1	80 ± 3.0	84.0	3.0 -0.7	4.0
1¼	100 ± 3.0	100.0	3.5 -0.7	5.0
1½	106 ± 3.5	106.5	3.5 -0.7	5.5
2	110 ± 3.5	116.0	4.0 -0.7	5.0
2½	120 ± 3.5	120.5	4.5 -1.0	4.7
3	130 ± 3.5	130.5	5.0 -1.0	5.2
4	140 ± 3.5	140.5	6.0 -1.0	6.1

All dimensions are in mm

Technical Drawing
DRAWING

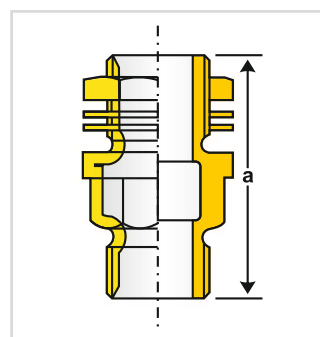

Cross - C1

90° Female, Equal

- Follow plus tolerance of BIS.
- Hot galvanised with thick uniform zinc coating.
- Accurate threading & perfectly angled to 180°.
- Superior grade malleability to ensure crack free installation.



NOMINAL SIZE (inches)	SPECIFIED DIMENSIONS & TOLERANCE (a)	OBSERVED DIMENSIONS (a)	SPECIFIED WALL THICKNESS & TOLERANCE	OBSERVED WALL THICKNESS
1/2	28 ± 1.5	29.0	2.5 -0.5	3.0
3/4	33 ± 2.0	33.3	3.0 -0.7	3.5
1	38 ± 2.0	38.0	3.0 -0.7	3.5
1¼	45 ± 2.0	45.8	3.5 -0.7	3.5
1½	50 ± 2.0	50.5	3.5 -0.7	4.5
2	58 ± 2.5	59.0	4.0 -0.7	5.0
2½	69 ± 2.5	68.8	4.5 -1.0	4.5
3	78 ± 3.0	79.0	5.0 -1.0	6.0
4	96 ± 3.0	97.5	6.0 -1.0	7.2

All dimensions are in mm

Technical Drawing
DRAWING

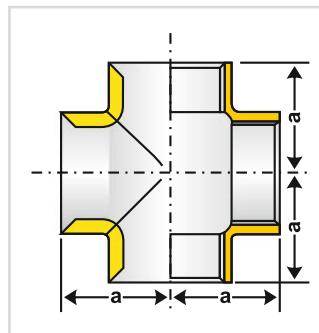

Bushing - N4

180° Male-Female, Reducing

- Follow plus tolerance of BIS.
- Hot galvanised with thick uniform zinc coating.
- Accurate threading & perfectly angled to 180°.
- Superior grade malleability to ensure crack free installation.



NOMINAL SIZE (inches)	SPECIFIED DIMENSIONS & TOLERANCE (a)	OBSERVED DIMENSIONS (a)	SPECIFIED WALL THICKNESS & TOLERANCE	OBSERVED WALL THICKNESS
3/4 x 1/2	26 ± 1.5	27.2	3.0 -0.7	3.8
1 x 1/2	29 ± 1.5	29.3	3.0 -0.7	3.1
1 x 3/4	29 ± 1.5	29.3	3.0 -0.7	3.0
1¼ x 1/2	31 ± 2.0	31.2	3.5 -0.7	3.8
1¼ x 3/4	31 ± 2.0	31.2	3.5 -0.7	3.8
1¼ x 1	31 ± 2.0	31.2	3.5 -0.7	3.8
1½ x 1/2	31 ± 2.0	31.5	3.5 -0.7	4.0
1½ x 3/4	31 ± 2.0	31.5	3.5 -0.7	4.0
1½ x 1	31 ± 2.0	31.5	3.5 -0.7	4.0
1½ x 1¼	31 ± 2.0	31.5	3.5 -0.7	4.0
2 x 1/2	35 ± 2.0	36.0	4.0 -0.7	4.5
2 x 3/4	35 ± 2.0	36.0	4.0 -0.7	4.5
2 x 1	35 ± 2.0	36.0	4.0 -0.7	4.5
2 x 1¼	35 ± 2.0	36.0	4.0 -0.7	4.5
2 x 1½	35 ± 2.0	36.0	4.0 -0.7	4.5

All dimensions are in mm

Technical Drawing
DRAWING

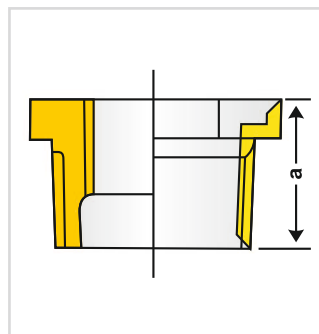

Bend - G4

90° Male-Female, Equal

- Follow plus tolerance of BIS.
- Hot galvanised with thick uniform zinc coating.
- Accurate threading & perfectly angled to 180°.
- Superior grade malleability to ensure crack free installation.



NOMINAL SIZE (inches)	SPECIFIED DIMENSIONS & TOLERANCE (a)	OBSERVED DIMENSIONS (a)	SPECIFIED DIMENSIONS & TOLERANCE (b)	OBSERVED DIMENSIONS (b)	SPECIFIED WALL THICKNESS & TOLERANCE	OBSERVED WALL THICKNESS
1/2	55 ± 2.5	55.3	48 ± 2.0	48.0	2.5 -0.5	3.8
3/4	69 ± 2.5	69.0	60 ± 2.5	60.0	3.0 -0.7	4.0
1	85 ± 3.0	85.5	75 ± 2.5	75.5	3.0 -0.7	3.5
1¼	105 ± 3.5	108.0	95 ± 3.0	95.0	3.5 -0.7	5.0
1½	116 ± 3.5	116.0	105 ± 3.5	107.0	3.5 -0.7	6.0
2	140 ± 3.5	142.0	130 ± 3.5	133.0	4.0 -0.7	6.0
2½	176 ± 4.0	176.0	165 ± 4.0	165.5	4.5 -1.0	8.0
3	205 ± 5.0	205.1	190 ± 4.0	191.5	5.0 -1.0	8.0
4	260 ± 5.0	262.0	245 ± 5.0	247.0	6.0 -1.0	8.5

All dimensions are in mm

Technical Drawing
DRAWING

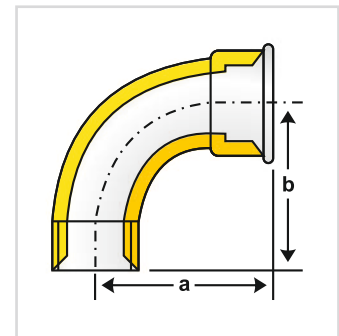

Male & Female Elbow - A4

90° Male-Female, Equal

- Follow plus tolerance of BIS.
- Hot galvanised with thick uniform zinc coating.
- Accurate threading & perfectly angled to 180°.
- Superior grade malleability to ensure crack free installation.



NOMINAL SIZE (inches)	SPECIFIED DIMENSIONS & TOLERANCE (a)	OBSERVED DIMENSIONS (a)	SPECIFIED DIMENSIONS & TOLERANCE (b)	OBSERVED DIMENSIONS (b)	SPECIFIED WALL THICKNESS & TOLERANCE	OBSERVED WALL THICKNESS
1/2	28 ± 1.5	28.1	37 ± 2.0	37.0	2.5 -0.5	3.0
3/4	33 ± 2.0	35.0	43 ± 2.0	43.4	3.0 -0.7	3.0
1	38 ± 2.0	38.0	52 ± 2.5	53.0	3.0 -0.7	4.5
1¼	45 ± 2.0	45.6	60 ± 2.5	60.5	3.5 -0.7	5.0
1½	50 ± 2.0	50.0	65 ± 2.5	65.0	3.5 -0.7	5.0
2	58 ± 2.5	59.0	74 ± 2.5	74.0	4.0 -0.7	5.0

All dimensions are in mm

Technical Drawing
DRAWING

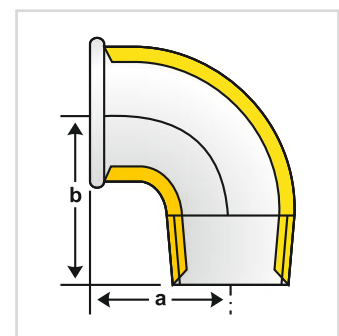

Side Outlet Elbow (3 Way) - Za1

90° Female, Equal

- Follow plus tolerance of BIS.
- Hot galvanised with thick uniform zinc coating.
- Accurate threading & perfectly angled to 180°.
- Superior grade malleability to ensure crack free installation.



Technical Drawing
DRAWING

NOMINAL SIZE (inches)	SPECIFIED DIMENSIONS & TOLERANCE (a)	OBSERVED DIMENSIONS (a)	SPECIFIED WALL THICKNESS & TOLERANCE	OBSERVED WALL THICKNESS
1/2	28 ± 1.5	28.0	2.5 -0.5	3.0
3/4	33 ± 2.0	33.0	3.0 -0.7	3.5
1	38 ± 2.0	38.0	3.0 -0.7	3.5
1¼	45 ± 2.0	45.5	3.5 -0.7	3.6
1½	50 ± 2.0	50.5	3.5 -0.7	3.8
2	58 ± 2.5	58.6	4.0 -0.7	4.0

All dimensions are in mm

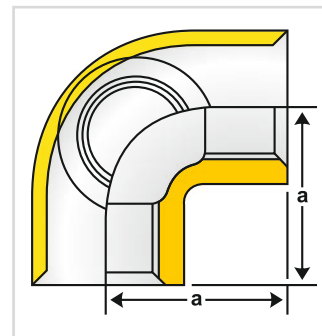

Side Outlet Tee (4 Way) - Za2

90° Female, Equal

- Follow plus tolerance of BIS.
- Hot galvanised with thick uniform zinc coating.
- Accurate threading & perfectly angled to 180°.
- Superior grade malleability to ensure crack free installation.



Technical Drawing
DRAWING

NOMINAL SIZE (inches)	SPECIFIED DIMENSIONS & TOLERANCE (a)	OBSERVED DIMENSIONS (a)	SPECIFIED WALL THICKNESS & TOLERANCE	OBSERVED WALL THICKNESS
1/2	28 ± 1.5	28.0	2.5 -0.5	3.0
3/4	33 ± 2.0	33.0	3.0 -0.7	3.0
1	38 ± 2.0	38.0	3.0 -0.7	4.0
1¼	45 ± 2.0	45.5	3.5 -0.7	4.0
1½	50 ± 2.0	50.5	3.5 -0.7	4.0
2	58 ± 2.5	58.2	4.0 -0.7	5.0

All dimensions are in mm

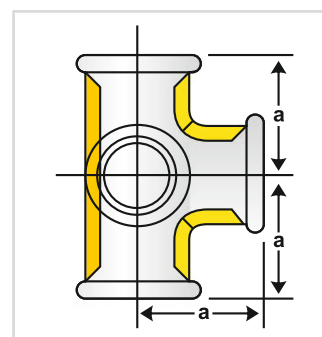

Plug - T8

Male Solid

- Follow plus tolerance of BIS.
- Hot galvanised with thick uniform zinc coating.
- Accurate threading.
- Superior grade malleability.



NOMINAL SIZE (inches)	SPECIFIED DIMENSIONS & TOLERANCE (a)	OBSERVED DIMENSIONS (a)	SPECIFIED WALL THICKNESS & TOLERANCE	OBSERVED WALL THICKNESS
1/2	18 ± 1.5	19.5	2.5 -0.5	3.8
3/4	20 ± 1.5	21.5	3.0 -0.7	3.8
1	23 ± 1.5	24.5	3.0 -0.7	4.0
1¼	29 ± 1.5	29.0	3.5 -0.7	4.5
1½	30 ± 1.5	31.0	3.5 -0.7	4.7
2	36 ± 2.0	36.0	4.0 -0.7	4.7
2½	39 ± 2.0	39.0	4.5 -1.0	4.5
3	44 ± 2.0	45.5	5.0 -1.0	5.5
4	58 ± 2.5	58.0	6.0 -1.0	7.1

All dimensions are in mm

Technical Drawing
DRAWINGS

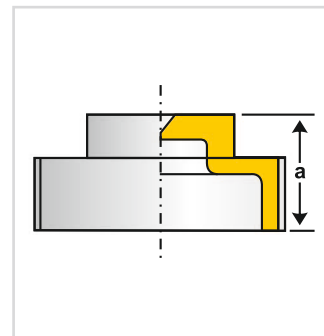

Back Nut - P4

180° Female, Equal

- Follow plus tolerance of BIS.
- Hot galvanised with thick uniform zinc coating.
- Accurate threading & perfectly angled to 180°.
- Superior grade malleability to ensure crack free installation.



NOMINAL SIZE (inches)	SPECIFIED DIMENSIONS & TOLERANCE (a)	OBSERVED DIMENSIONS (a)	SPECIFIED WALL THICKNESS & TOLERANCE	OBSERVED WALL THICKNESS
1/2	08 ± 1.5	09.0	2.5 -0.5	3.0
3/4	09 ± 1.5	10.5	3.0 -0.7	3.3
1	10 ± 1.5	11.2	3.0 -0.7	3.5
1¼	11 ± 1.5	11.7	3.5 -0.7	3.7
1½	12 ± 1.5	12.4	3.5 -0.7	3.7
2	13 ± 1.5	13.6	4.0 -0.7	4.2
2½	16 ± 1.5	16.5	4.5 -1.0	4.7
3	19 ± 1.5	19.5	5.0 -1.0	5.5
4	22 ± 1.5	22.5	6.0 -1.0	6.5

All dimensions are in mm

Technical Drawing
DRAWINGS

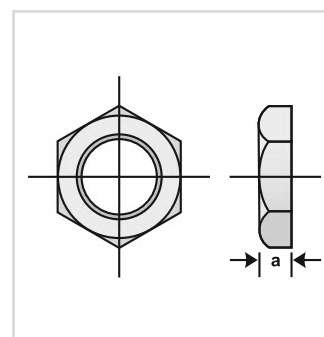

Flange

180° Female

- Hot Galvanised with thick uniform zinc coating.
- Accurate threading & perfectly angled to 180°.
- Superior grade malleability to ensure crack free installation.



NOMINAL SIZE (inches)	OBSERVED DIMENSIONS (a)	OBSERVED DIAMETER (d)
1/2	15.0	75.5
3/4	18.0	85.5
1	19.0	90.5
1¼	20.0	110.5
1½	20.0	114.5
2	21.0	140.5
2½	22.0	159.0
3	24.0	176.0
4	26.0	200.5
6	32.5	269.5

All dimensions are in mm

Technical Drawing
DRAWINGS

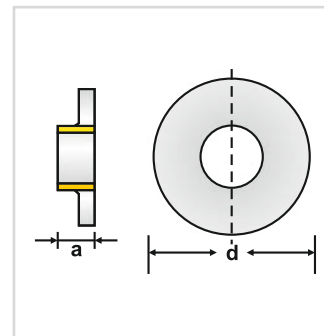

Barrel Nipple (B. Class)

180° Male

- Accurate threading & perfectly angled to 180°.
- Best quality 'B' class pipe used to ensure life long installation.



NOMINAL SIZE (inches)	OBSERVED NOMINAL BORE (d)	OBSERVED OUTER DIAMETER (D)
1/2	15.0	21.0
3/4	20.0	26.0
1	25.0	33.0
1¼	32.0	42.0
1½	40.0	48.0
2	50.0	60.0
2½	65.0	76.0
3	80.0	88.0
4	100.0	114.0
5	125.0	140.0
6	150.0	166.0

All dimensions are in mm

Technical Drawing
DRAWINGS

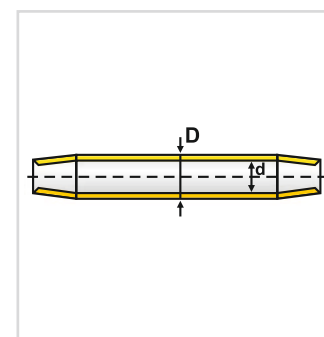



Nozzle Nipple

180° Male

- Hot galvanised with thick uniform zinc coating.
- Accurate threading & perfectly angled to 180°.
- Superior grade malleability to ensure crack free installation.



Technical Drawing

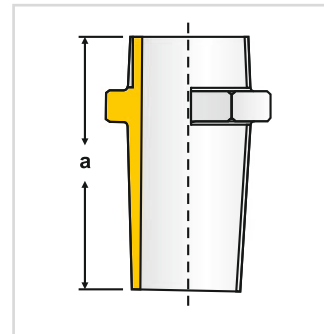

NOMINAL SIZE (inches)	OBSERVED DIMENSIONS (a)	OBSERVED WALL THICKNESS
1/2	60.0	3.2
3/4	70.0	3.5
1	68.0	4.0

All dimensions are in mm

Approved & Registered

 Indian Railways/ICF/DLW/ RCF & COS of all regions.	 MES (Defence)/Airforce/ Ordnance Factories.	 Coalfields (SCCL, WCL, ECL, CCL, SECL)	 Nuclear Power Corporation of India	 इंडियन ऑयल	 हिन्दुस्तान पेट्रोलियम	 एनटीपीसी NTPC
 सेल SAIL	 मोयल MOIL Manganese Ore (India) Ltd.	 Hindustan Zinc Ltd.	 Bhakra Beas Management Board	 McNally Bharat Engineering Company	 SAHARA INDIA PAPER	 DLF BUILDING INDIA
 LARSEN & TOUBRO	 unitech Bengal Unitech Universal Infrastructure	 Nagarjuna Fertilizers & Chemicals Nagarjuna Construction Company	 IVRCL IVRCL Infrastructures & Projects	 SHIRKE B G Shirke Construction Technology	 tyco Tyco Engineering & Construction	 Simplex Infrastructures
 SOBHA DEVELOPERS	 Ahluwalia Contracts	 East Coast Constructions & Industries Ltd.	 Oberoi Hotels & Resorts	 TAJ Hotels Resorts and Palaces	 Hirco Hiranandani Infrastructure & Real Estate Company	 TATA MEDICAL CENTER
 VOLTAS LIMITED	 TECHNO INDIA GROUP	 Mfar CONSTRUCTIONS	 K RAHEJA CORP	 Shapoorji Pallonji & Co. Ltd.	 JAYPEE PROJECTS	 emami INFRACTURE
 SOUTH CITY	 BLUE STAR	 Bengal DCL	 FORT GROUP The Fourth Dimension of Space	 Tantia CONSTRUCTIONS LIMITED	 AmbujaRealty™	 avaniGROUP An ISO 9001 & 14001 Organisation
 ORBIT GROUP	 srijan Building Tomorrows	 MERLIN GROUP Quality Homes By Quality People	 BELANI BUILDS BETTER	 Controller of Stores Punjab & Maryana	Contact us for more References	



STANDARD PACKING LIST

ITEM	1/4	3/8	1/2	3/4	1	1¼	1½	2	2½	3	4	5	6
ELBOW	1200	1100	550	350	250	160	110	60	35	24	12	6	4
TEE	900	800	350	250	160	100	70	40	22	15	8	4	3
SOCKET	1200	1200	800	550	350	225	175	100	50	40	20	10	8
UNION	400	350	300	225	170	110	80	55	30	20	12	6	4
HEX NIPPLE	1200	1100	1000	600	380	225	175	100	50	40	20	-	-
TANK NIPPLE	-	-	400	300	150	100	80	40	25	20	10	-	-
CROSS	-	-	350	240	140	80	60	30	15	12	6	-	-
BEND	-	-	500	250	150	80	60	30	15	10	3	-	-
MALE & FEMALE ELBOW	-	-	450	300	200	110	100	50	-	-	-	-	-
SIDE OUTLET ELBOW (3 WAY)	-	-	500	300	180	110	100	40	-	-	-	-	-
SIDE OUTLET TEE (4 WAY)	-	-	300	200	125	80	60	30	-	-	-	-	-
PLUG	-	-	2000	1000	650	400	275	175	100	75	50	-	-
BACK NUT	-	-	1500	1000	700	500	400	250	200	200	150	-	-
C.L.SOLID PLUG	-	-	2000	1000	650	400	275	175	100	75	50	-	-
FLANGE	-	-	325	270	225	130	125	70	60	45	40	-	15
BARREL NIPPLE (B. CLASS)	Quantity Varies as per Nipple Length, Please Contact us to know more.												
NOZZLE NIPPLE	-	-	600	600	380	-	-	-	-	-	-	-	-
	3/8 x 1/4	1/2 x 1/4	1/2 x 3/8	3/4 x 1/4	3/4 x 3/8	3/4 x 1/2	1 x 1/4	1 x 3/8	1 x 1/2	1 x 3/4	1¼ x 1/2	1¼ x 3/4	1¼ x 1
REDUCING ELBOW	1000	1000	1000	-	-	500	-	-	350	300	225	225	200
REDUCING TEE	500	400	400	-	-	300	250	250	250	200	150	140	110
REDUCING SOCKET	1100	1000	1000	1000	1000	700	700	700	500	450	300	300	250
BUSHING	-	-	-	-	-	750	-	-	700	750	400	400	450
	1½ x 1/2	1½ x 3/4	1½ x 1	1½ x 1¼	2 x 1/2	2 x 3/4	2 x 1	2 x 1¼	2 x 1½	2½ x 1/2	2½ x 3/4	2½ x 1	2½ x 1¼
REDUCING ELBOW	200	200	150	125	120	110	100	80	75	50	50	50	50
REDUCING TEE	120	100	100	80	75	70	65	60	50	40	40	40	30
REDUCING SOCKET	225	225	200	180	150	140	125	120	120	70	70	70	60
BUSHING	275	275	350	400	300	300	250	200	200	-	-	-	-
	2½ x 1½	2½ x 2	3 x ½	3 x ¾	3 x 1	3 x 1¼	3 x 1½	3 x 2	3 x 2½	4 x 1/2	4 x 3/4	4 x 1	4 x 1¼
REDUCING ELBOW	50	40	40	40	40	30	30	30	30	40	30	30	30
REDUCING TEE	30	25	30	30	25	20	20	20	18	15	15	15	12
REDUCING SOCKET	60	60	55	55	55	50	50	50	40	25	25	25	25
	4 x 1½	4 x 2	4 x 2½	4 x 3	5 x 3/4	5 x 1	5 x 1¼	5 x 1½	5 x 2	5 x 2½	5 x 3	5 x 4	6 x 3/4
REDUCING ELBOW	25	20	15	15	-	-	-	-	-	-	-	-	-
REDUCING TEE	12	12	10	10	8	8	8	8	8	6	6	6	-
REDUCING SOCKET	25	25	20	20	-	12	12	12	12	10	10	10	10
	6 x 1	6 x 1¼	6 x 1½	6 x 2	6 x 2½	6 x 3	6 x 4	6 x 5					
REDUCING ELBOW	-	-	-	-	-	4	4	4					
REDUCING TEE	6	6	6	6	4	4	4	4					
REDUCING SOCKET	10	10	10	10	8	8	8	8					



We keep it safe !



HB INDUSTRIES

Bulandpur Road, Opp. Transport Nagar,
G.T. Road, Bye Pass, Jalandhar - 144 004 (Punjab) INDIA
Mobile : +91- 98158-90585, +91 78372 21288
Email : hbfittings@hbgroup.in
www.hbgroup.in



Pipe Fittings